

## Lesson 5

# Solid Modeling - Constructive Solid Geometry

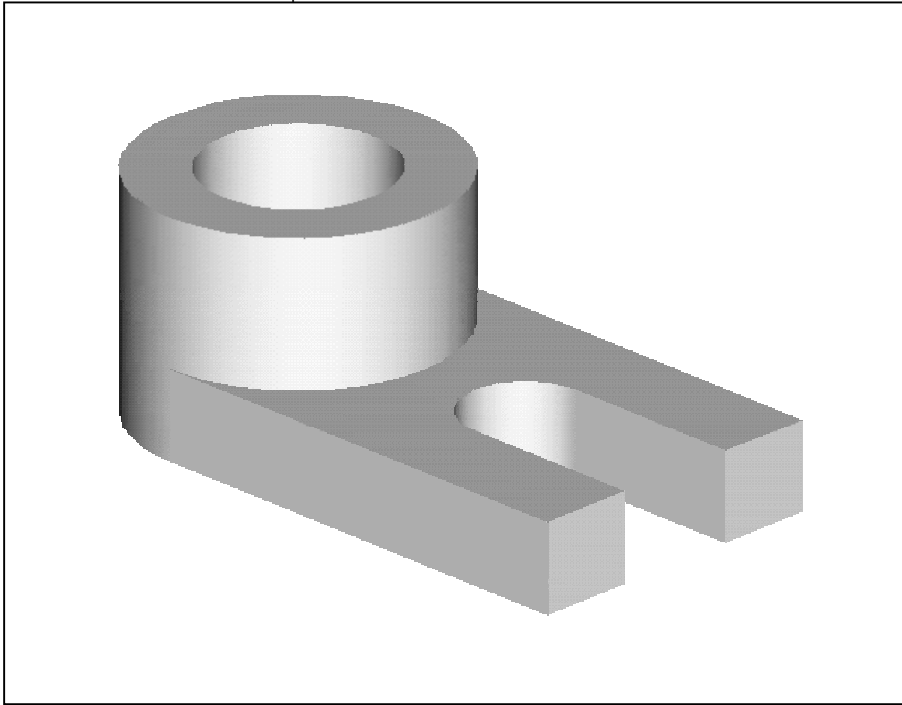

## Learning Objectives

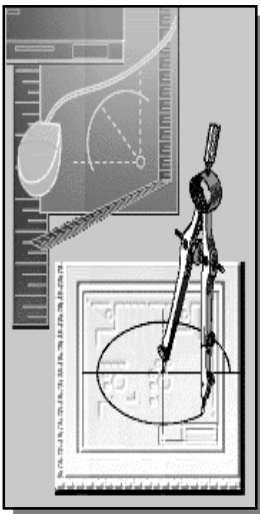

- ◆ Understand the Constructive Solid Geometry Concept.
- ◆ Create a Binary Tree.
- ◆ Understand the basic Boolean Operations.
- ◆ Create Solids using AutoCAD Primitive Solids.
- ◆ Generate Shaded SOLID images.
- ◆ Use the Dynamic Rotation – 3D Orbit command.

## Introduction

Design includes all activities involved from the original concept to the finished product. Design is the process by which products are created and modified. For many years designers sought ways to describe and analyze three-dimensional designs without building physical models. Although orthographic projections can be used to provide much of the information, they still require designers to translate between the three-dimensional object and flat two-dimensional views. With the advancements in computer technology, the creation of three-dimensional models on computers offers a wide range of benefits. Computer models are easier to interpret and can be altered easily. Computer models can be analyzed using finite element analysis software, and simulation of real-life loads can be applied to the computer models and the results graphically displayed.

There are three basic types of three-dimensional computer geometric modeling methods: wireframe modeling, surface modeling and solid modeling. The 3-D wireframe models contain information about the locations of all the points and edges in space coordinates. The 3-D models can be viewed from any direction as needed and are reasonably good representations of 3-D objects. But because surface definition is not part of a wireframe model, all wireframe images have the inherent problem of ambiguity.

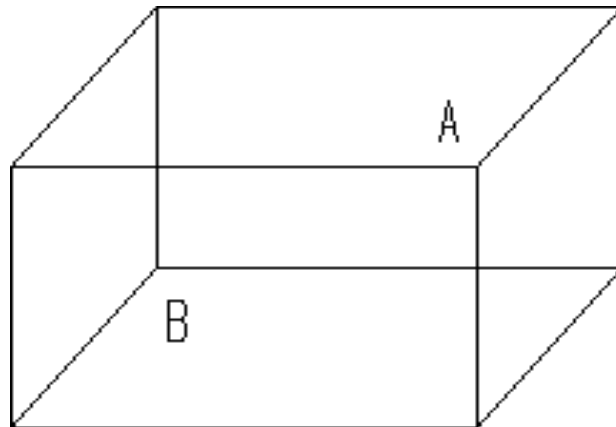

**Wireframe Ambiguity:** Which corner is in front, A or B?

Surface modeling describes part surfaces but not interiors. Designers are still required to interactively examine surface models to insure that the various surfaces on a model are contiguous throughout. Many of the concepts used in 3-D wireframe and surface modelers are incorporated in the solid modeling scheme, but it is solid modeling that offers the most advantages as a design tool.

In the solid modeling presentation scheme, the solid definitions include nodes, edges, and surfaces, and it is a complete and unambiguous mathematical representation of a precisely enclosed and filled volume. Two predominant methods for representing solid models are the **constructive solid geometry (CSG)** representation and the **boundary representation (B-rep)**. CSG defines a model in terms of combining basic solid shapes and B-rep defines a model in terms of its edges and surfaces. AutoCAD's solid modeler is a hybrid modeler; the user interface and construction techniques are CSG-based, whereas the B-rep capabilities are invoked automatically and are transparent to the user.

In this lesson, we will discuss the fundamental concepts of solid modeling. We will demonstrate the procedure required to construct a solid model using AutoCAD's CSG-based user interface.

## The Guide-Block Design

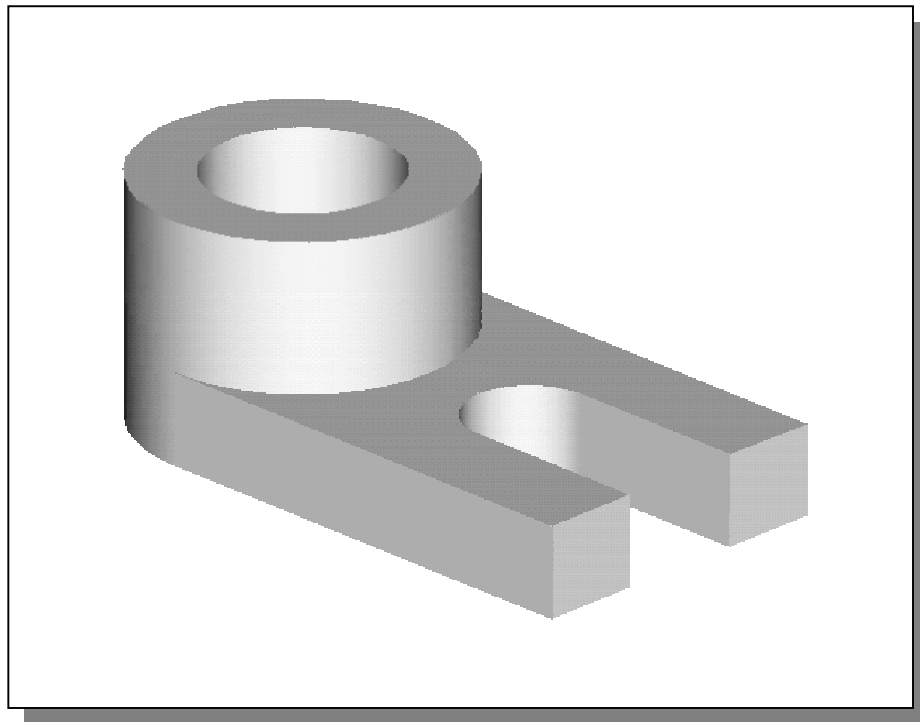

## Constructive Solid Geometry concept

In the 1980s, one of the main advancements in **Solid Modeling** was the development of the **Constructive Solid Geometry** (CSG) method. CSG describes the solid model as the combination of basic three-dimensional shapes (**primitive solids**). The basic primitive solid set typically includes: Rectangular-prism (Block), Cylinder, Cone, Sphere, and Torus (Donut). Two solid objects can be combined into one object in various ways, these operations are known as **Boolean operations**. There are three basic Boolean operations: **UNION (Join)**, **SUBTRACT (Cut)**, and **INTERSECT**. The UNION operation combines the two volumes included in the different solids into a single solid. The SUBTRACT operation subtracts the volume of one solid object from the other solid object. The INTERSECT operation keeps only the volume common to both solid objects. The CSG method is also known as the **Machinist's Approach**, as the method is parallel to machine shop practices.

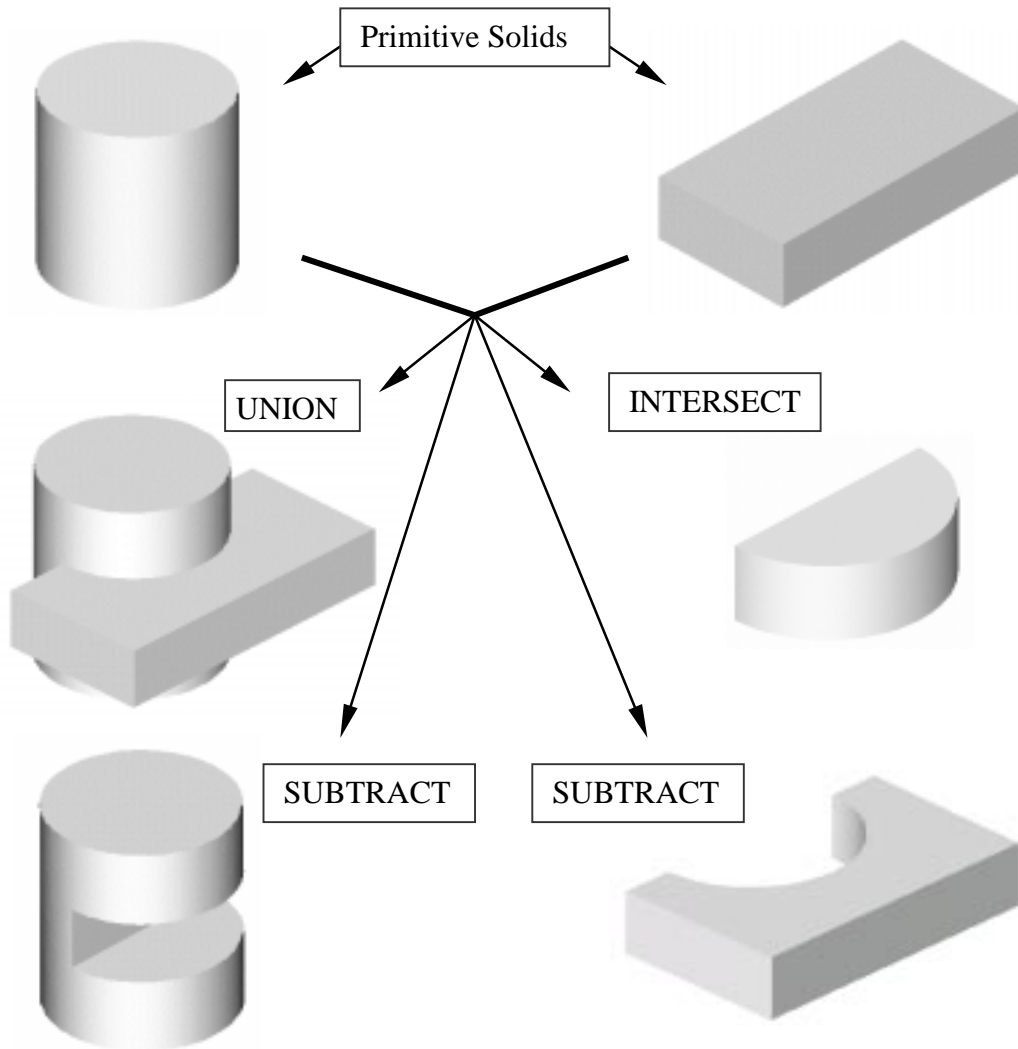

## Binary Tree

The CSG is also referred to as the method used to store a solid model in the database. The resulting solid can be easily represented by what is called a **binary tree**. In a binary tree, the terminal branches (leaves) are the various primitives that are linked together to make the final solid object (the root). The binary tree is an effective way to represent the steps required to construct the solid model. Complicated solid models can be modeled by considering the different combinations of Boolean operations required in the binary tree. This provides a convenient and intuitive way of modeling that imitates the manufacturing process. A binary tree is an effective way to plan your modeling strategy before you start creating anything.

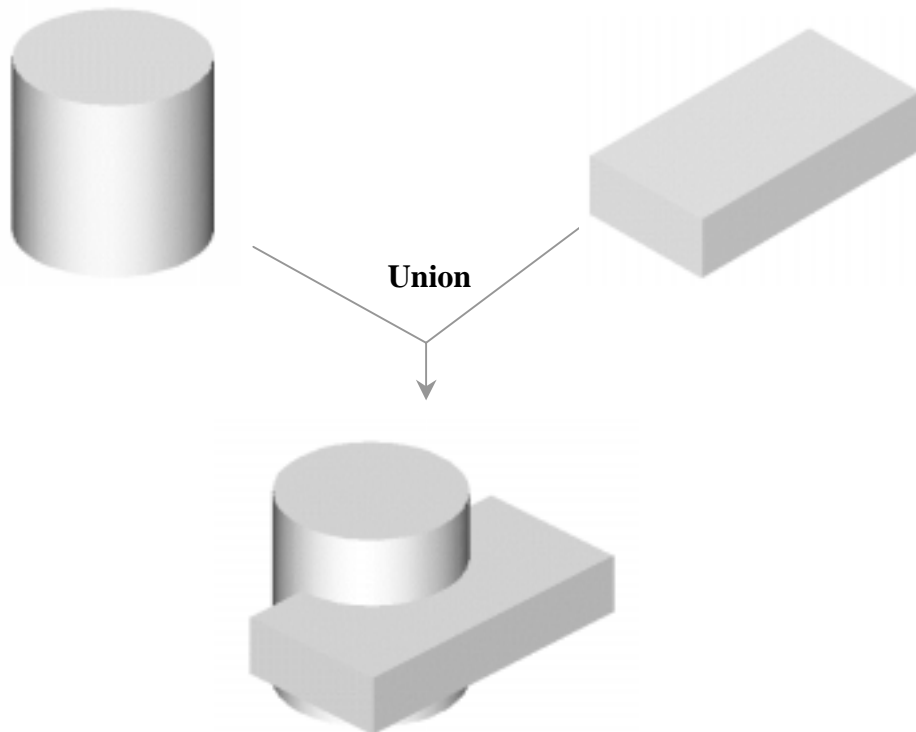
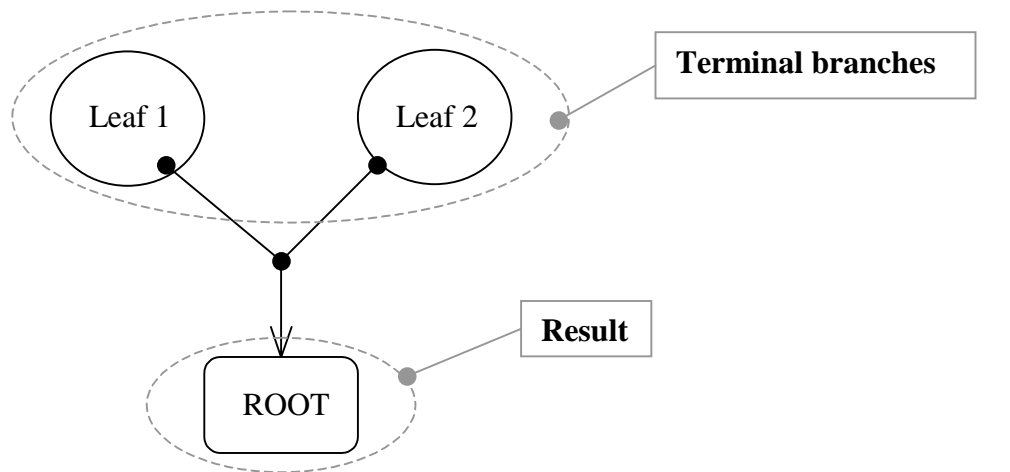

## The Guide-Block CSG Binary Tree

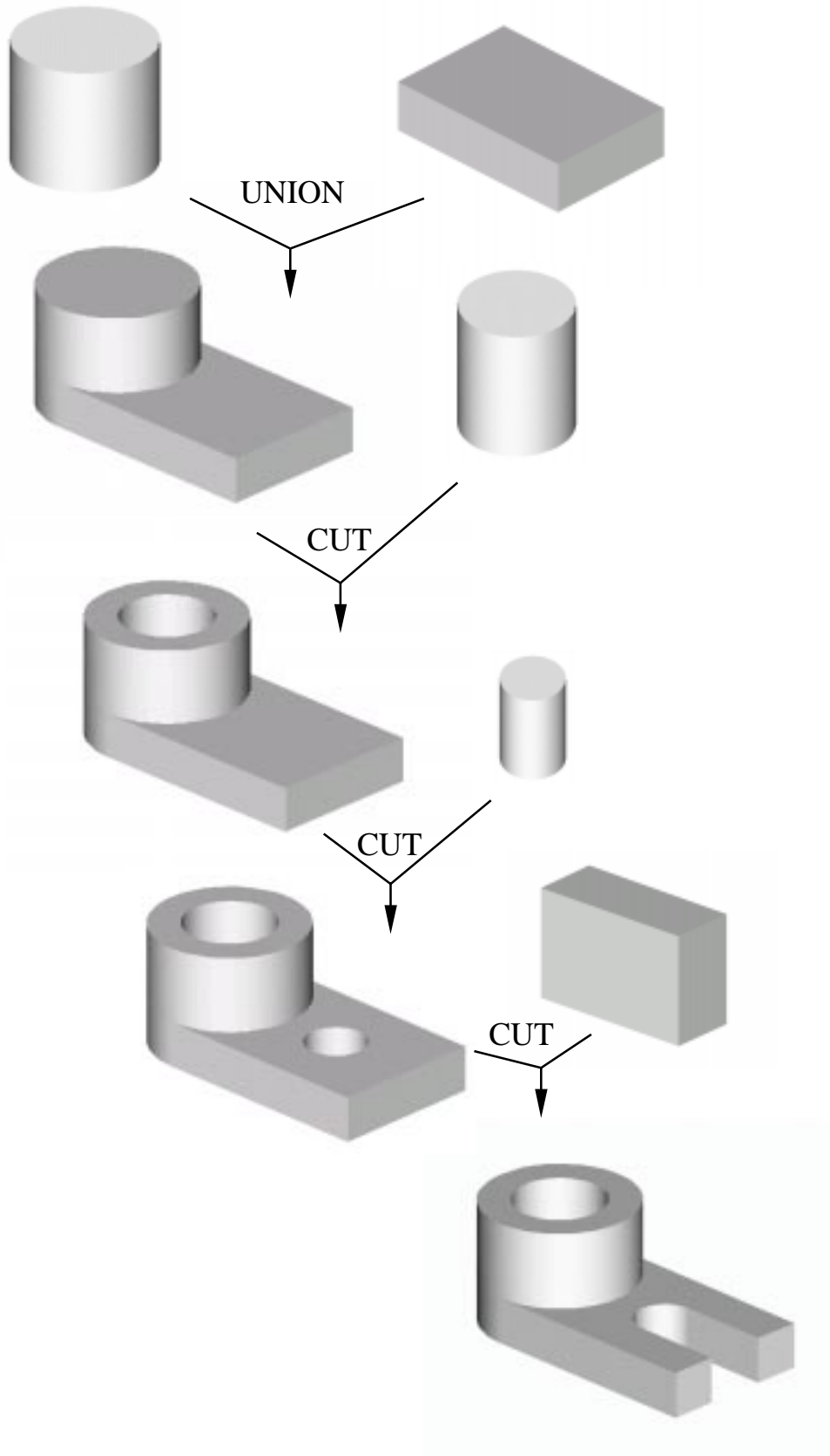

## Starting Up AutoCAD 2000i

1. Select the AutoCAD 2000i option on the *Program* menu or select the AutoCAD 2000i icon on the *Desktop*.
2. In the *AutoCAD Today* startup dialog box, select the **Create Drawings** tab with the single click of the left-mouse-button.
3. In the startup dialog box, select the **Start from Scratch** icon with a single click of the left-mouse-button.

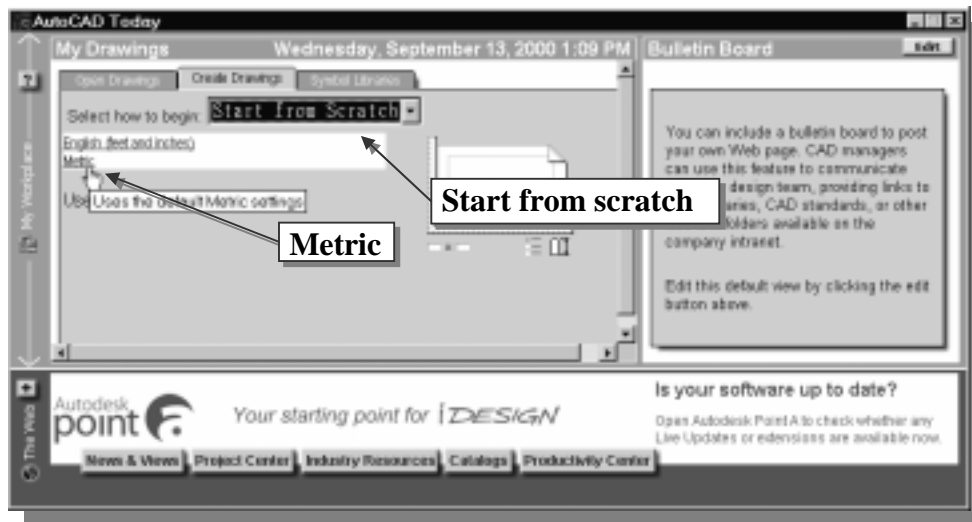

4. In the *Default Settings* section, pick **Metric** as the drawing units.



5. Close the *Drawing1* window by clicking the **Close** icon located at the upper-right-corner of the *Drawing1* window.



6. Pick **Layers** in the *Object Properties* toolbar.

7. Click the **New** icon to create a new layer.
8. Create a **new layer** with the following settings:

<i>Layer</i>	<i>Color</i>	<i>LineType</i>
<b>Solid_Objects</b>	<b>Cyan</b>	<b>Continuous</b>

9. Set layer **Solid\_Objects** as the *Current Layer*.



10. Click on the **OK** button to accept the settings and exit the *Layer Properties Manager* dialog box.

## Creating the first 3-D object

1. In the *Status Bar* area, reset the option buttons so that only *POLAR*, *OSNAP*, *OTRACK*, and *MODEL* are switched *ON*.

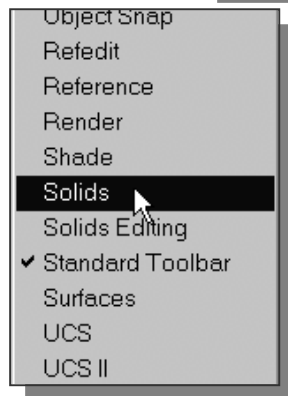

2. Move the cursor to the *Standard* toolbar area and **right-click** on any icon of the *Standard* toolbar to display a list of toolbar menu groups.
3. Select ***Solids***, with the left-mouse-button, to display the *Solids* toolbar on the screen.

- The first section of the *Solids* toolbar contains the basic set of solids available in AutoCAD 2000i.

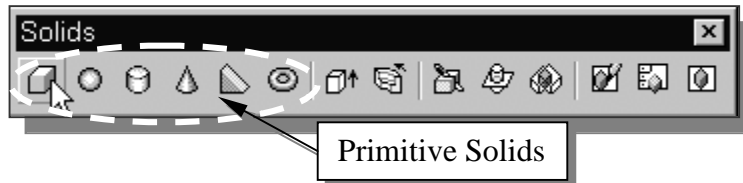

- We will first create a **75 x 50 x 15** rectangular block.

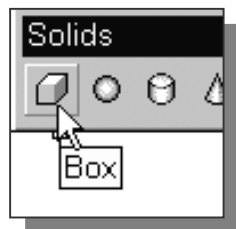

4. In the *Solids* toolbar, click on the ***Box*** icon. In the command prompt area, the message “*Specify corner of box or [Ccenter] <0,0,0>:*” is displayed.
5. Pick a location that is near the lower-left corner of the graphics window.
6. In the command prompt area, the message “*Specify corner or [Cube/Length]:*” is displayed. Enter: **@75,50 [ENTER]**.
7. In the command prompt area, the message “*Specify Height:*” is displayed. Enter: **15 [ENTER]**.

## Viewing the 3-D block

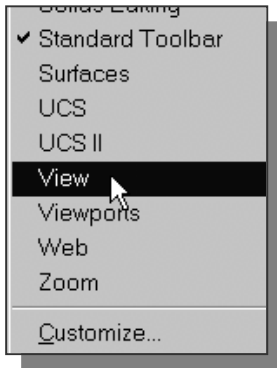

1. Move the cursor to the *Standard* toolbar area and **right-click** on any icon of the *Standard* toolbar to display a list of toolbar menu groups.
2. Select *View*, with the left-mouse-button, to display the *View* toolbar on the screen.

- The *View* toolbar contains two sections of icons that allow us to quickly switch to standard 2-D and 3-D views.

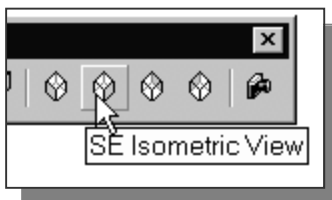
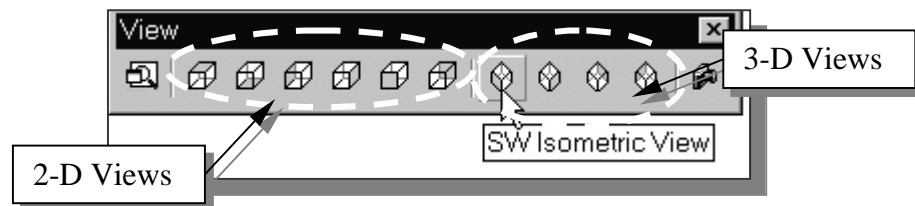

3. In the *View* toolbar, click on the *SE Isometric View* icon.

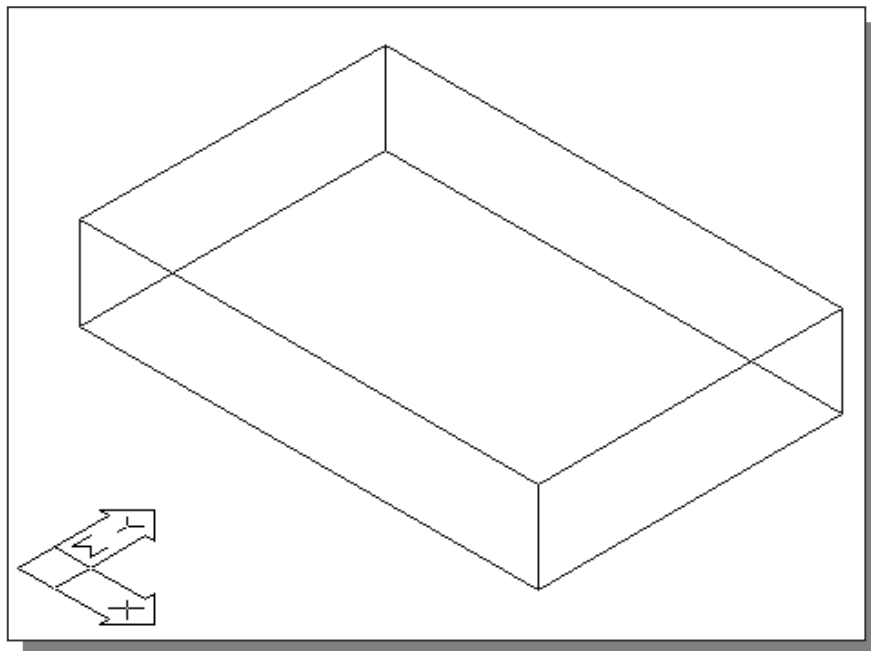

## Creating the second solid feature

- We will next create a cylinder block as the second solid feature.

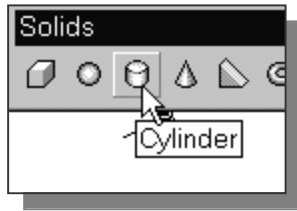

- In the *Solids* toolbar, click on the **Cylinder** icon. In the command prompt area, the message “Specify center point for base cylinder or [Elliptical] <0,0,0>:” is displayed.
- Inside the graphics window, press down the **[SHIFT]** key and **right-mouse-click** once to bring up the *Object Snap* shortcut menu.

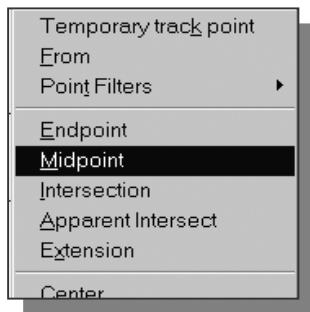

- Select the **Midpoint** option in the shortcut menu. Snap to and select the midpoint of the left-bottom edge of the rectangular block as shown.
  - In the command prompt area, the message “Specify radius for base of cylinder or [Diameter]:” is displayed. Snap to and select one of the endpoints of the bottom edge of the rectangular block.
5. In the command prompt area, the message “Specify height of cylinder or [Center of other end]:” is displayed. Enter: **50 [ENTER]**.

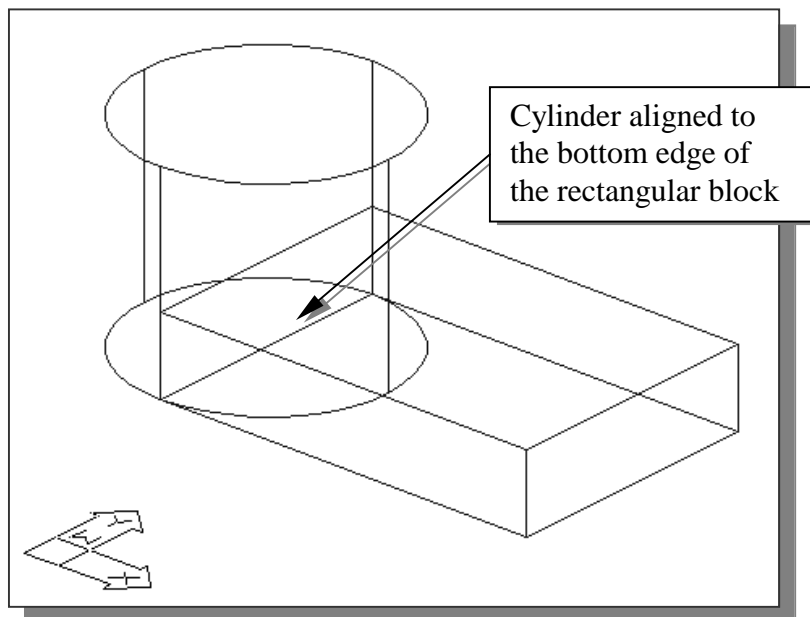

- Two solid objects, one rectangular box and one cylinder, are displayed on the screen.

## Boolean operation - *UNION*



1. Move the cursor to the *Standard* toolbar area and **right-click** on any icon of the *Standard* toolbar to display a list of toolbar menu groups.
2. Select ***Solids Editing***, with the left-mouse-button, to display the *Solids Editing* toolbar on the screen.

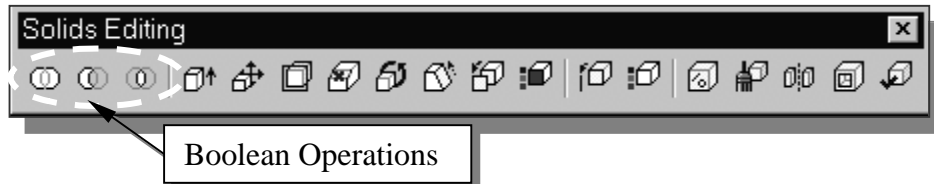

- The first section of the *Solids Editing* toolbar contains the basic set of Boolean operation icons.

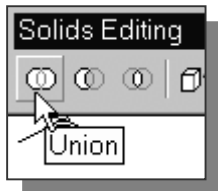

3. In the *Solids Editing* toolbar, click on the ***Union*** icon. In the command prompt area, the message "*Select Objects:*" is displayed.
4. Pick both solids by clicking on their edges.

5. Inside the graphics window, **right-mouse-click** to accept the selection and proceed with the *UNION* command.

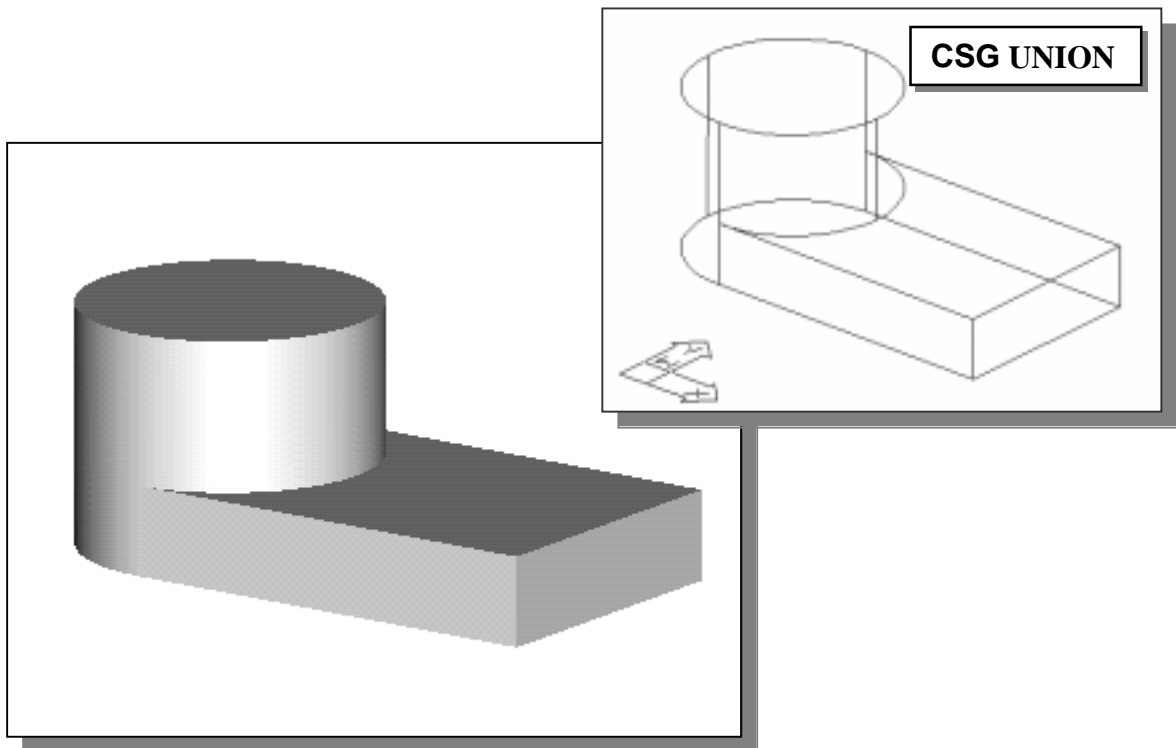

## Creating the second cylinder feature

We will create another cylinder as the next solid feature.

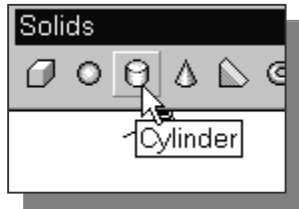

1. In the *Solids* toolbar, click on the **Cylinder** icon. In the command prompt area, the message “*Specify center point for base cylinder or [Elliptical] <0,0,0>:*” is displayed.
2. Inside the graphics window, press down the **[SHIFT]** key and **right-mouse-click** once to bring up the *Object Snap* shortcut menu.
  3. Select the **Center** option in the shortcut menu.
  4. Snap to and select the **center of the circle** that is at the top of the solid block.
  5. In the command prompt area, the message “*Specify radius for base of cylinder or [Diameter]:*” is displayed. Enter: **15 [ENTER]**.
  6. In the command prompt area, the message “*Specify height of cylinder or [Center of other end]:*” is displayed. Enter: **-60 [ENTER]**.  
(The negative value will extrude the cylinder downward, in the negative Z direction.)

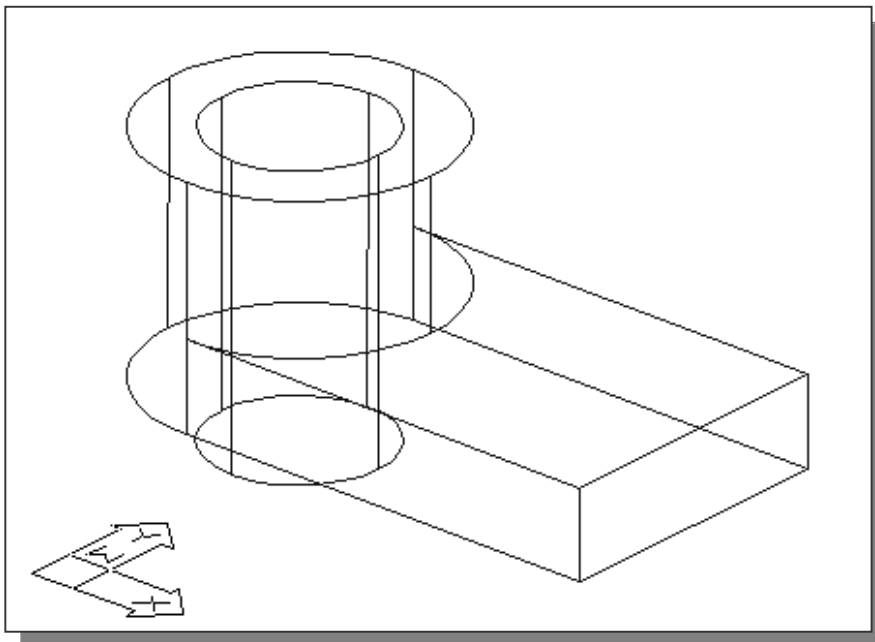

- Two solid objects, the base block and a cylinder, are displayed on the screen. On your own, use the *FRONT VIEW* and *TOP VIEW* options to confirm the top of the two solids are aligned. (Before continuing, restore the view as shown; including the *Coordinate* icon.)

## Boolean operation - ***SUBTRACT***

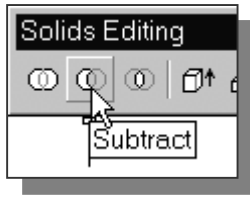

1. In the *Solids Editing* toolbar, click on the ***Subtract*** icon. In the command prompt area, the message “\_subtract Select solids and regions to subtract from .. Select Objects:” is displayed.
2. Pick the base block solid by clicking on one of the straight edges.
3. Inside the graphics window, **right-mouse-click** to accept the selection and proceed with the *SUBTRACT* command.
4. In the command prompt area, the message “ Select solids and regions to subtract .. Select Objects:” is displayed.
5. Pick the cylinder block by clicking on one of the circular edges.
6. Inside the graphics window, **right-mouse-click** to accept the selection and proceed with the *SUBTRACT* command.

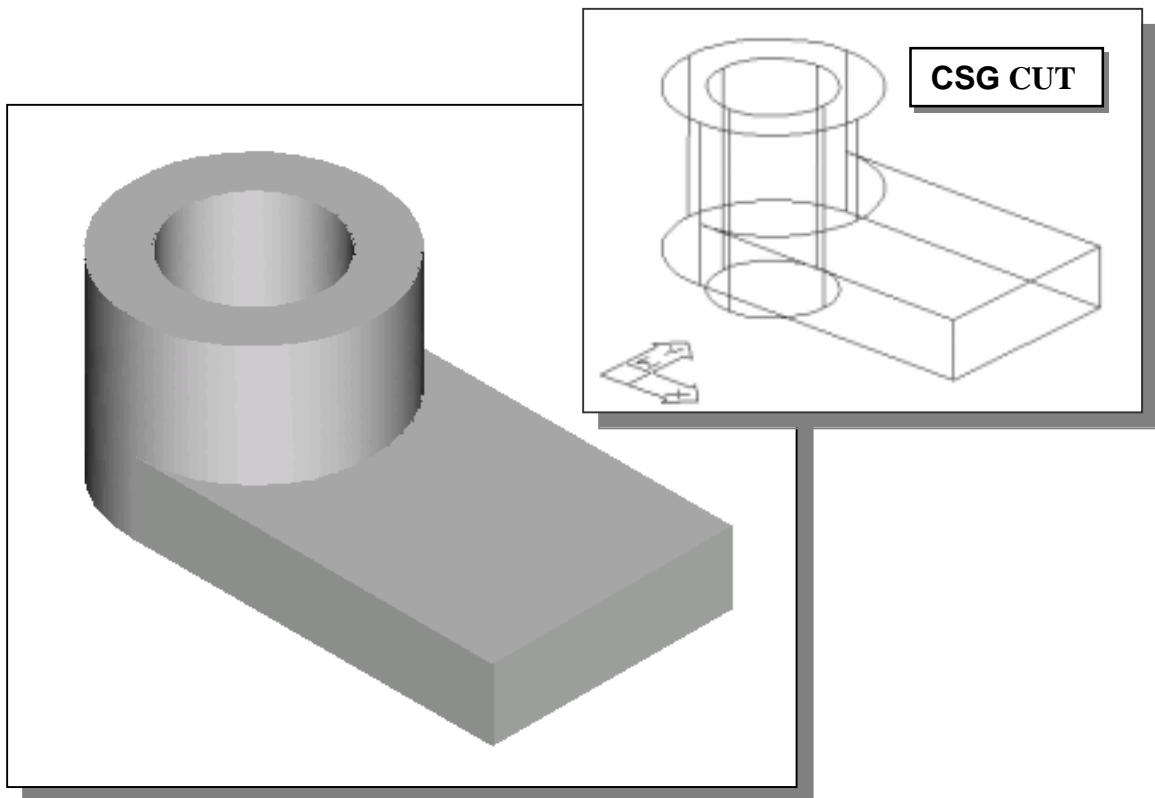

## Creating another solid feature

As can be seen, the CSG construction approach is quite straightforward. The main task is in positioning and aligning the solid blocks prior to applying the Boolean operation.

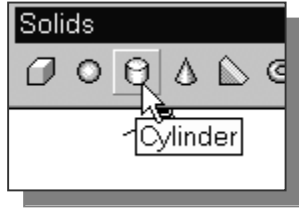

1. In the *Solids* toolbar, click on the **Cylinder** icon. In the command prompt area, the message “*Specify center point for base cylinder or [Elliptical] <0,0,0>:*” is displayed.
2. Inside the graphics window, press down the **[SHIFT]** key and **right-mouse-click** once to bring up the *Object Snap* shortcut menu.

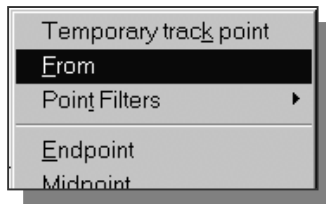

3. Select the **From** option in the shortcut menu.
4. Snap to the top-front corner of the base block and enter: **@-30,25 [ENTER]**.
5. In the command prompt area, the message “*Specify radius for base of cylinder or [Diameter]:*” is displayed. Enter: **10 [ENTER]**.
6. In the command prompt area, the message “*Specify height of cylinder or [Center of other end]:*” is displayed. Enter: **-30 [ENTER]**.

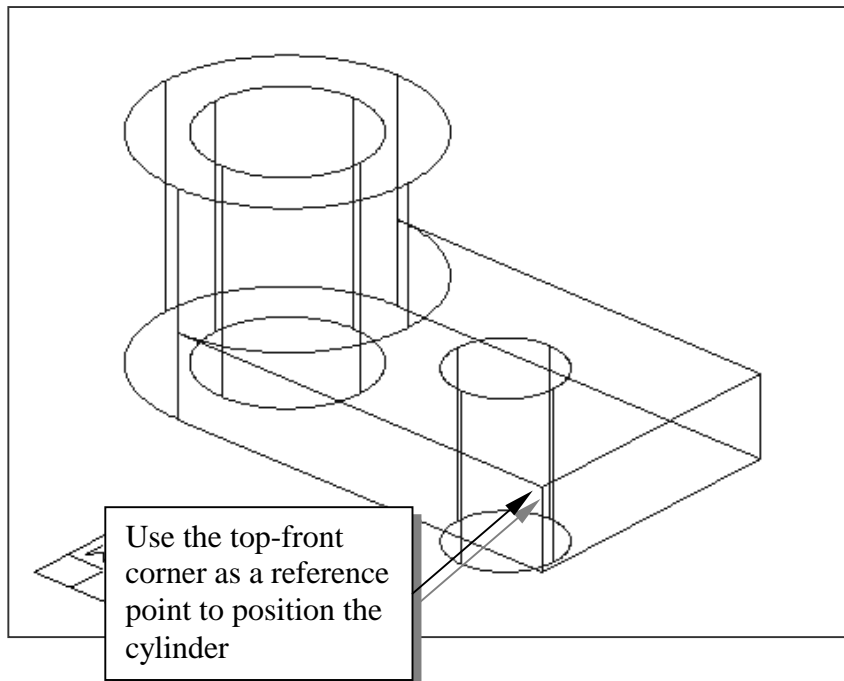

7. On your own, perform the Boolean **SUBTRACT** operation.

## Shaded SOLID

1. Move the cursor to the *Standard* toolbar area and **right-click** on any icon of the *Standard* toolbar to display a list of toolbar menu groups.
2. Select *Shade*, with the left-mouse-button, to display the *Shade* toolbar on the screen.

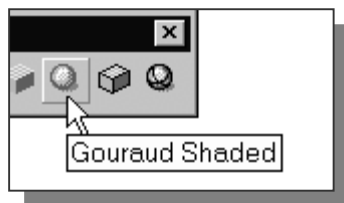
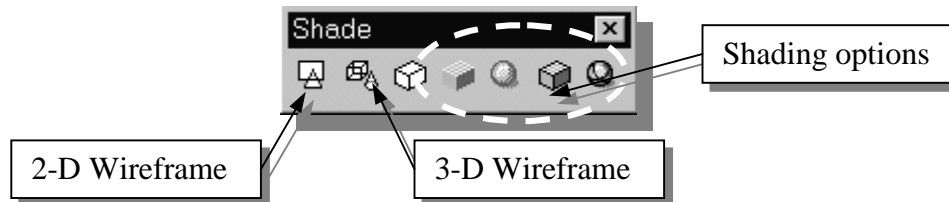

3. In the *Shade* toolbar, click on the *Gouraud Shaded* icon. This method produces a relatively smooth shaded solid.
  - On your own, examine the effects of the other *Shading* options.

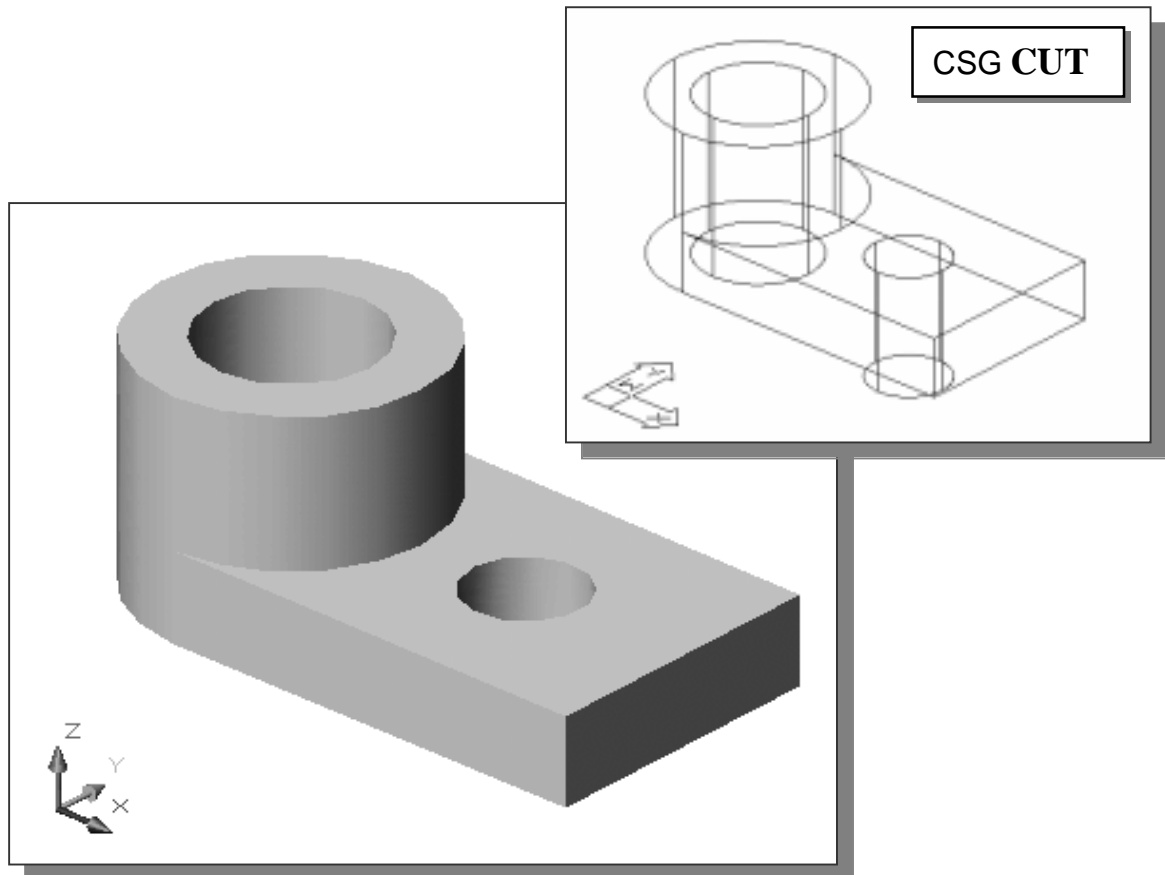

## Creating the final feature

We will create a rectangular cut as the final solid feature of the part. In the previous sections, with some careful planning, we positioned the solid blocks at the correct space locations while we were creating the solids. It is also possible to take a more general approach to orient and position solid blocks in space coordinates.

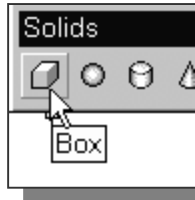

1. In the *Solids* toolbar, click on the **Box** icon. In the command prompt area, the message “*Specify corner of box or [Ccenter] <0,0,0>:*” is displayed.
2. Snap to and select the **top-front corner** of the base block.
3. In the command prompt area, the message “*Specify corner or [Cube/Length]:*” is displayed. Enter: **@-30,30 [ENTER]**.
4. In the command prompt area, the message “*Specify Height:*” is displayed. Enter: **20 [ENTER]**.

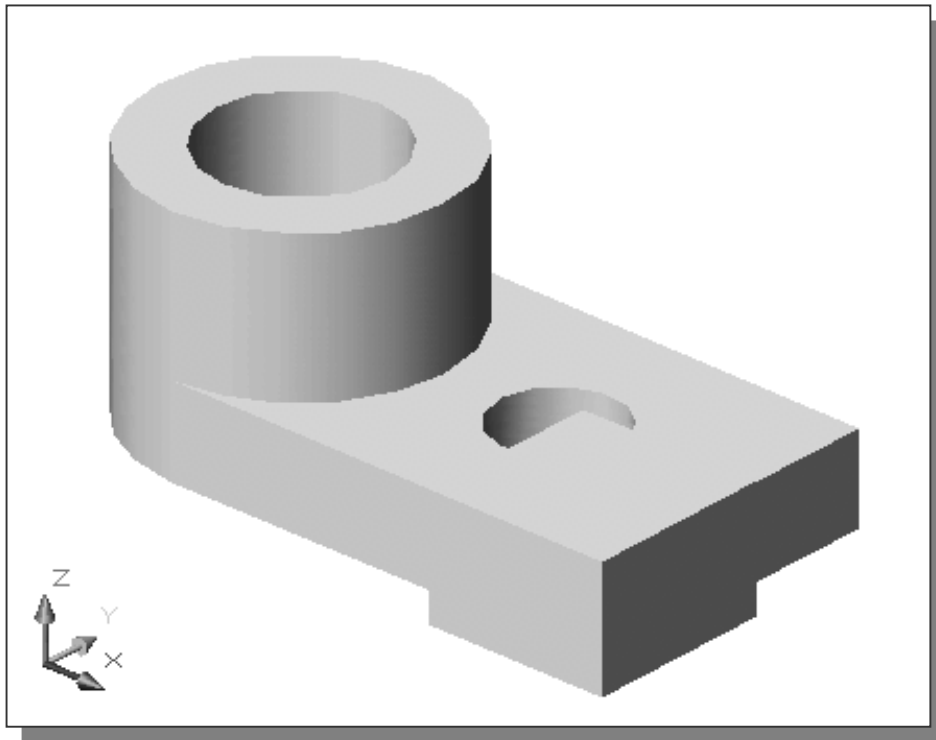

- Two overlapping solids appear on the screen. We will use the *editing tools* to orient the cutter, the rectangular block, to its correct location.

## Rotating the rectangular block

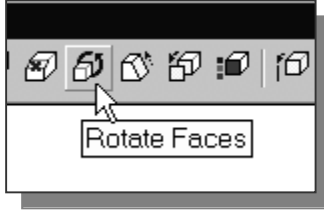

1. In the *Solids Editing* toolbar, click on the **Rotate Faces** icon. In the command prompt area, the message “*Select Faces or [Undo/Remove/All]:*” is displayed.
2. Select the edges of the rectangular block until **all edges are highlighted** as shown.

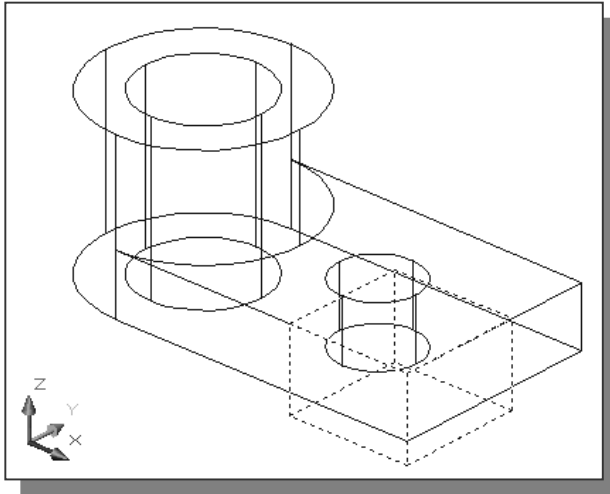

3. Inside the graphics window, **right-mouse-click** and select **Enter** in the popup option menu to proceed with the *ROTATE* command.
4. In the command prompt area, the message “*Specify an axis point or [Axis by object /View /Xaxis /Yaxis /Zaxis]<2 points>:*” is displayed. Inside the graphics window, **right-mouse-click** and select **Xaxis** in the popup option menu to proceed with the *ROTATE* command.

5. In the command prompt area, the message “*Specify the origin of the rotation <0,0,0>:*” is displayed. Pick the top-front corner of the rectangular block as the rotation origin.

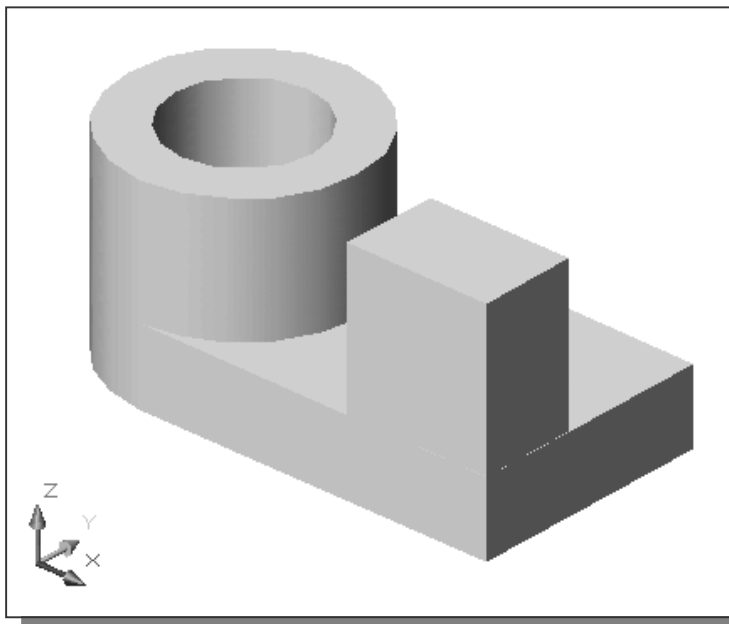

6. In the command prompt area, the message “*Specify a rotation angle or [Reference]:*” is displayed.  
Enter: **90 [ENTER]**.
7. Inside the graphics window, **right-mouse-click** and select **Exit** in the popup menu.
8. **Right-mouse-click** inside the graphics window and select **Exit** to exit the *ROTATE* command.

9.

## Moving the Rectangular Block

1. **Pre-select** the rectangular block by left-clicking on any edge of the block.
2. Inside the graphics window, **right-mouse-click** and select **Move** in the popup menu. In the command prompt area, the message “*Specify base point or displacement:*” is displayed.
3. Snap to and select the **top-front corner** of the rectangular block as the reference point.

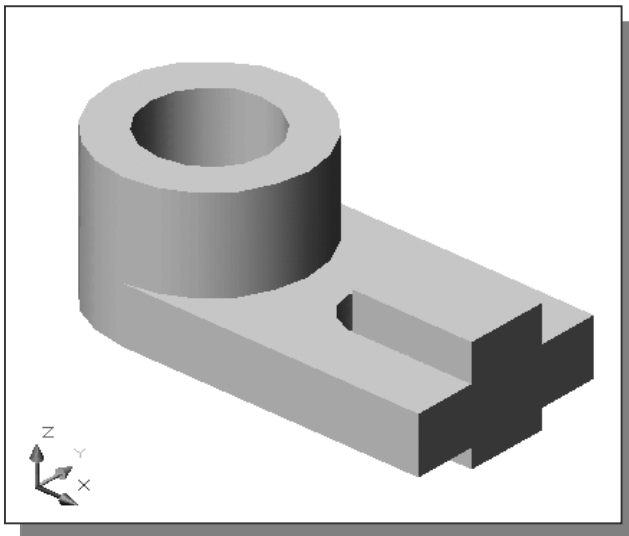

4. In the command prompt area, the message “*Specify second point of displacement or <use first point as displacement>:*” is displayed.  
Enter: **@0,15,-20 [ENTER]**.

## Dynamic rotation – 3D orbit



1. Click on the **3D Orbit** icon in the *Standard* toolbar.

The *3D-Orbit* view displays an **arcball**, which is a circle, divided into four quadrants by smaller circles. *3D-Orbit* enables us to manipulate the view of 3D objects by clicking and dragging with the left-mouse-button.

2. Inside the *arcball*, press down the left-mouse-button and drag it up and down to rotate about the screen X-axis.

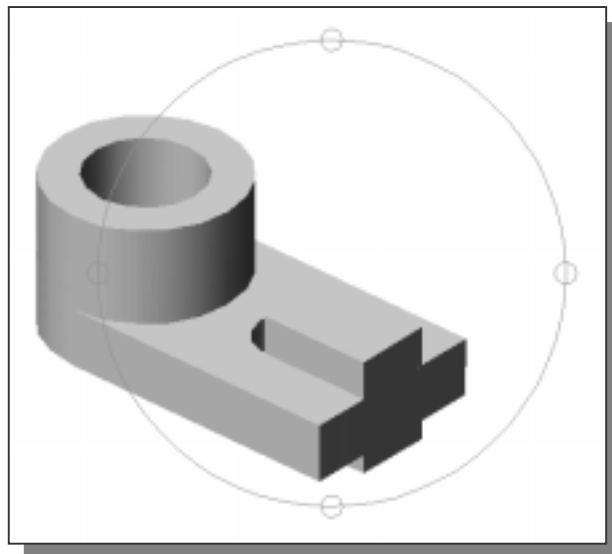

3. Move the cursor to different location on the screen, outside the *arcball* or on one of the four small circles, and experiment with the real-time dynamic rotation feature of the *3D-ORBIT* command.
4. On your own, perform the *SUBTRACT BOOLEAN* operation.

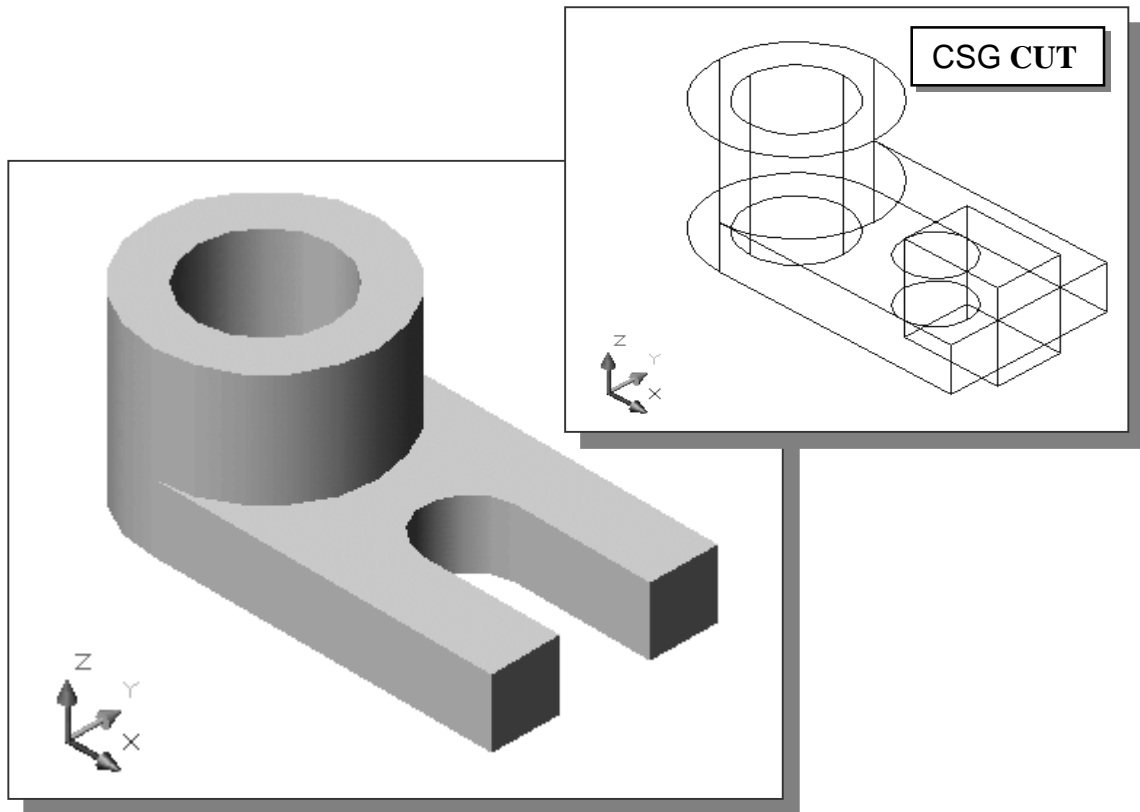

## Conclusion

Throughout this text, various CAD techniques have been presented. Mastering these techniques will enable you to be effective and productive in creating CAD designs. In many instances, only a single approach to the construction tasks was presented; you are encouraged to repeat any of the lessons and develop different ways of thinking in accomplishing the same tasks. We have only covered the fundamentals of AutoCAD's functionality. The more time you spend using the system, the easier it will be to perform Computer Aided Design with AutoCAD 2000i.

## Questions:

1. What are the three basic Boolean operations commonly used in computer geometric modeling software?
2. What is a *primitive solid*?
3. What does *CSG* stand for?
4. Which Boolean operation keeps only the volume common to the two solid objects?
5. What is the difference between a *CUT* feature and a *UNION* feature in AutoCAD?
6. Using the CSG concept, create Binary Tree sketches showing the steps you plan to use to create the two models shown on the next page:

Ex.1)

Ex.2)



**Notes:**